

## Rewind unit 520-R1 with infeed

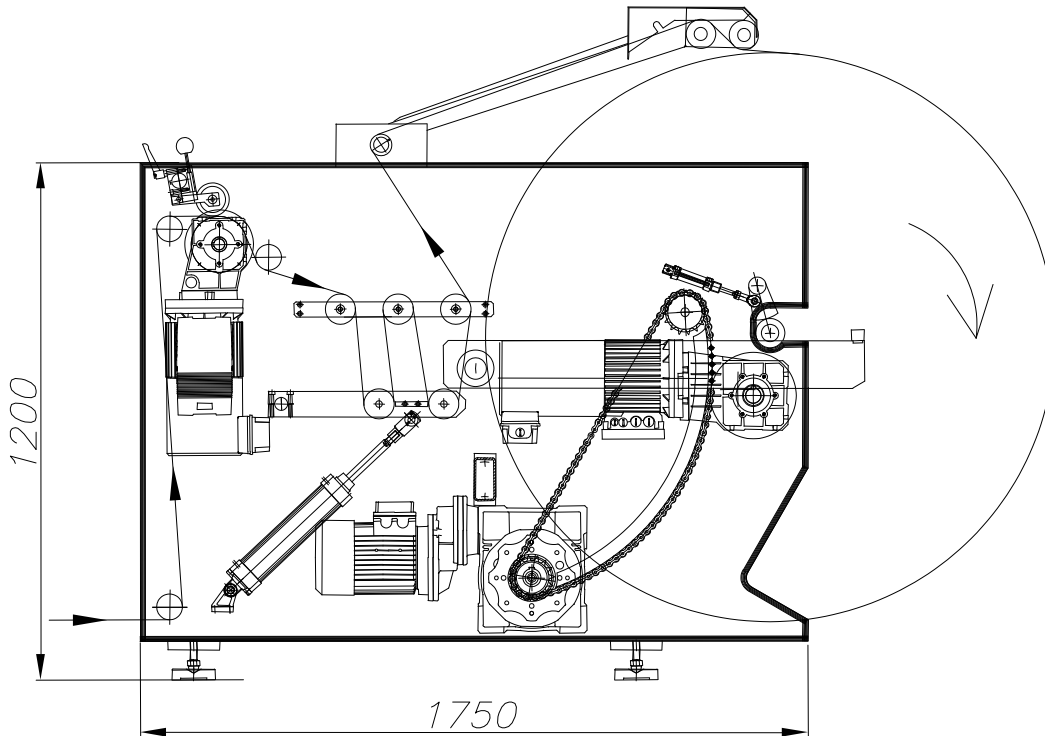

### Specifications:

Maximum paper width.....	520 mm
Maximum roll diameter.....	1.280 mm
Draw roller lift-off.....	Standard
2 Unwind directions	
Air shaft 70 mm	
Electrical roll lift	
Pull strength.....	400 N
Draw roller with EPDM coating.....	Standard
Electro-pneumatic reel support arm for exact winding....	Standard
Web break sensor.....	Standard
Rewind motor controlled by dancer roller	
Web tension control via dancer roller	
Web speed.....	0 – 3000 m.min
Infeed roller to control tension between print station and paper roll	
Side frames 30 mm	
Electrical connection 400V 3N PE 50Hz 32 A/C	
Air pressure.....	8 bar
Touch screen on covers	