

Unwind 520-U1 with outfeed

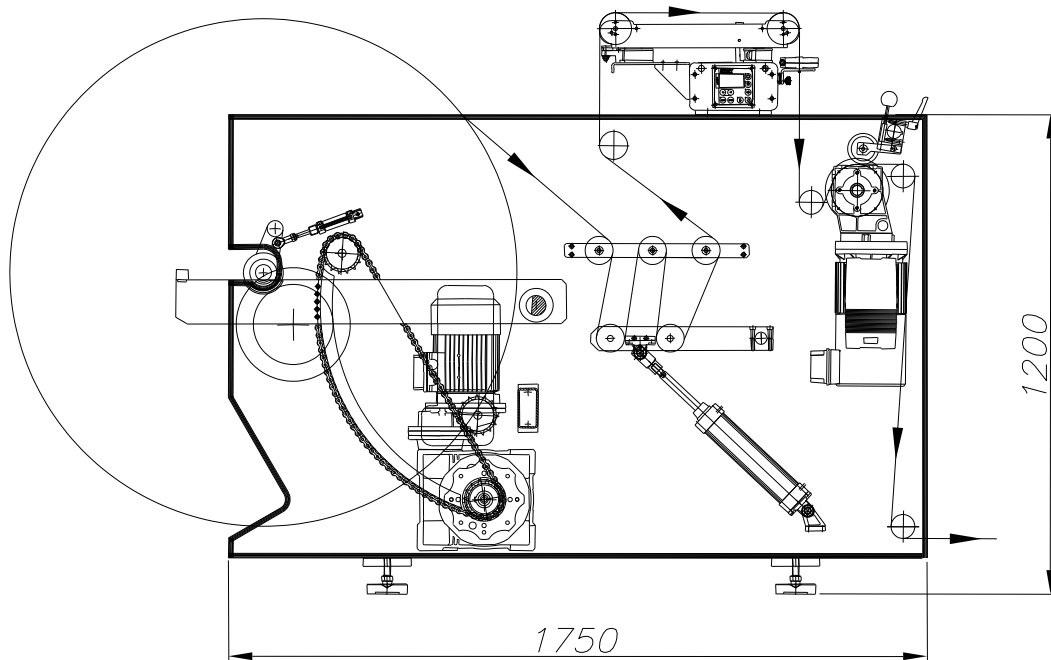

Specifications:

Maximum paper width.....	520 mm
Maximum roll diameter.....	1.280 mm
Web splice device	
2 Unwind directions	
Air shaft 70 mm	
Electrical roll lift	
Splice table w. pneum. Tension device.....	Standard
Brake power.....	400 N
Electronic web edge control.....	Optional
Roll end sensor.....	Standard
Brake via motor controlled by dancer roller	
Web tension control via dancer roller	
Web speed.....	0 – 180 m.min
Outfeed rollers to control tension between unwind and print station	
Side frames 20 mm	
Electrical connection 400V 3N PE 50Hz / 32 A/C	
Air pressure.....	6 bar