

# SEMI-TEC 350

TECTUPRINT COMBINED SEMI & ROTARY FINISHING EQUIPMENT

Introducing the perfect match **SEMI-TEC 350** a modular solution that running in Rotating mode and Semi Rotary mode to produce pre-printed solutions of digital products for self-adhesive labels and packaging market.

## Designed to cover an evolving market

- Flexo Printing on digital converting machines.
- 17" Die Cutting cylinder.
- Hot Stamping Formats.
- Flat Screen Printing.
- Unlimited online technologies to add value at digital products.

## TECHNICAL SPECIFICATIONS

- Máximum web width: 350 mm.
- Máximum printing/varnishing width: 340 mm.
- Máximum speed in Semy Rotary): 65 mt./min. (according to format)
- Máximum speed in Rotary 150 mt./min.

### UNWINDER:

- Unwinder for crolls of máximum  $\varnothing$  600 mm.
- Máximum width 340 mm. and core  $\varnothing$  76 mm.

### PRINTING MODULE:

- Flexographic printing group with servo-motorization Independent

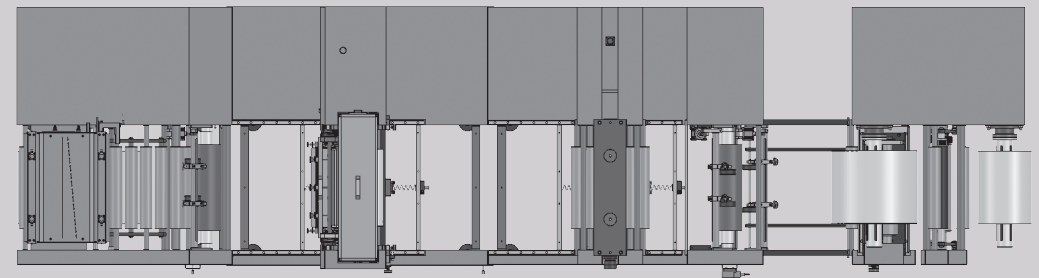
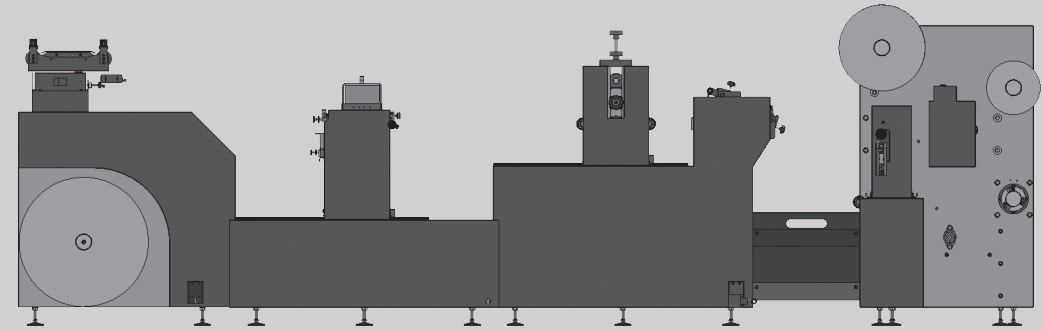
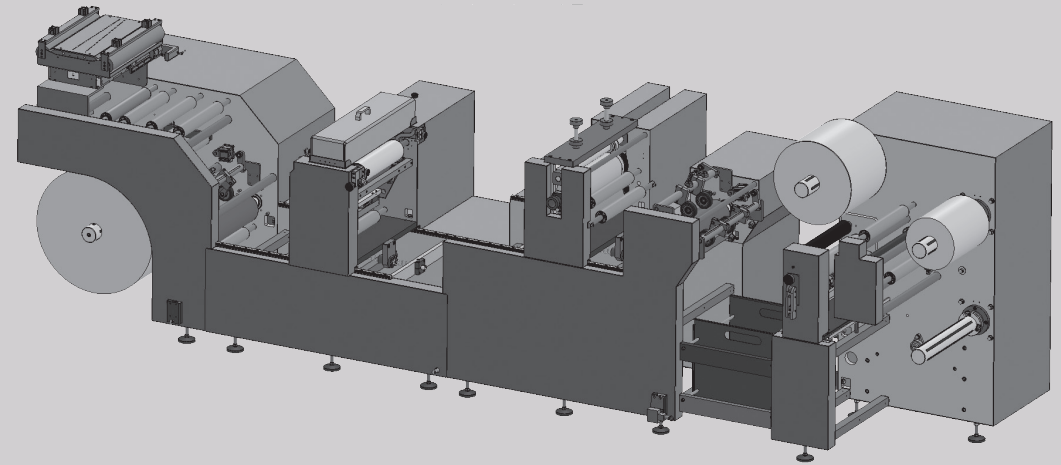

**tectu**PRINT  
Solutions for the Printing Industry  
[www.tectuprint.com](http://www.tectuprint.com)

- Longitudinal register micro-adjustment with spindle precision servo-motorized.
- Manual adjustment of the traverse register.
- Interchangeable anilox roller.
- Magnetic plate holder cylinder, 17" development.

#### CURING SYSTEMS:

- Hot Air (water-based inks)
- UV drying or LED UV

#### DIE-CUTTING MODULE:

- Rotary die-cutting group with servo motorization
- 17" development magnetic cylinder.
- Longitudinal register micro-adjustment with spindle precision servo-motorized.
- Manual adjustment for cross register.

#### REWINDER:

- Independent (pull) motorization activated by barriers reserves paper at the exit of the Outfeed.
- Longitudinal cutting head (Rotosystem system)
- Weaning group for coils of maximum Ø 400mm
- Double rewind position (with spindle interchangeable rewind) for different Ø of core.

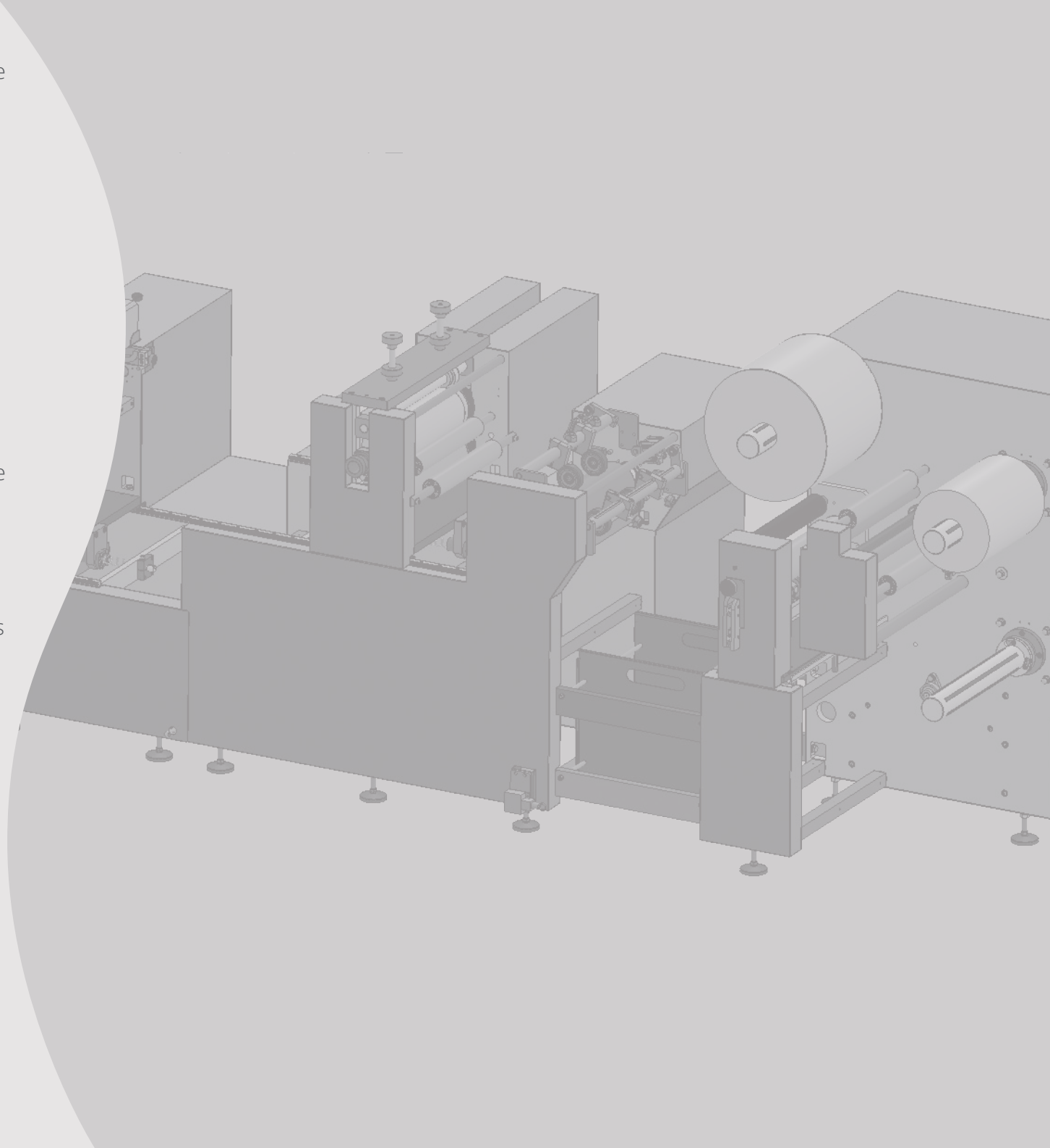

**tectu**PRINT **ERIEC**

Solutions for the Printing Industry

[www.tectuprint.com](http://www.tectuprint.com)

Pol. Ind. Casablanca C/ Empordà n° 29  
 09192 Sant Quirze del Valles, Barcelona (Spain)  
 Phone. +34 937-221-664 · Fax. +34 937-310-588 · [info@tectuprint.com](mailto:info@tectuprint.com)